

# Wideband Microwave Amplifier Design

By H. Paul Shuch, N6TX  
14908 Sandy Lane  
San Jose, CA 95124

## How High the Moon/How Wide the Band?

High frequency is a relative thing. Take the HF ham bands. (Please!) The only thing "High Frequency" about them to most microwavers is that they're fine for coordinating scheds (we've all heard our friends on 3818 kHz saying "I'm gonna send Os now"), and they make dandy IFs for *real* RF converters. True hams (and if you're reading this, that's you) long for the more exotic frequencies up the spectrum.

But one person's exotic is another's mundane. About fifteen years ago I applied for a position as a microwave receiver designer at a well-known aerospace company. I had recently developed and published a number of preamp, filter and mixer designs for the 23-cm amateur band, and thinking myself quite the microwave engineer, brought some manuscripts and prototypes along to the interview. "Interesting," was the manager's comment, and he hired me to work in the IF Amplifier Section.

Ah, but what IF amplifiers they were! This company was converting wide expanses of the millimeter waves down to the "lower spectrum" below 10 GHz! An early task to which I was assigned was the design of a 2- to 6-GHz amplifier with flat gain and noise figure. A challenge to be sure, as we hams seldom think in terms of true wideband performance. Our widest microwave bands are scarcely ten percent from end-to-end, and here I had to span an octave and a half. It turns out the project was a challenge to the professionals as well; before the amplifier was completed, a dozen engineers ended up occupying two large mainframe computers for the better part of a year. Broadbanding microwave circuitry, it seems, is no trivial task.

## Why so Narrow?

Solid-state microwave active devices tend to be frequency selective by nature. Consider the scattering parameters of the familiar MRF-901 silicon bipolar junction transistor, as seen in Table 1. Note that the magnitude of  $S_{21}$ , forward voltage transmission coefficient, diminishes predictably with frequency. Each time frequency doubles, this figure for unmatched forward voltage gain drops in half.

If we expressed gain logarithmically, we'd see that gain is rolling off at roughly six dB per octave—exactly the perfor-

Table 1

Scattering parameters for a typical microwave silicon bipolar junction transistor, the Motorola MRF-901, biased at 5 volts  $V_{ce}$  and 5 mA  $I_c$ . Note that beyond about 200 MHz,  $S_{21}$  decreases quite uniformly with frequency (see text).

FREQ	$S_{11}$		$S_{21}$		$S_{12}$		$S_{22}$	
	MAGN	ANG	MAGN	ANG	MAGN	ANG	MAGN	ANG
100	0.71	-38	11.3	153	0.03	68	0.92	-17
200	0.62	-75	9.48	133	0.05	55	0.76	-29
500	0.54	-141	5.4	100	0.07	43	0.48	-44
1000	0.53	178	2.93	76	0.09	48	0.40	-56
2000	0.59	130	1.51	48	0.16	62	0.35	-85

Table 2

Scattering parameters for a typical microwave gallium arsenide field effect transistor, the Avantek ATF10235 biased at 2 volts  $V_{ds}$  and 20 mA  $I_d$ . Note that beyond about 4 GHz,  $S_{21}$  decreases quite uniformly with frequency (see text).

FREQ	$S_{11}$		$S_{21}$		$S_{12}$		$S_{22}$	
	MAGN	ANG	MAGN	ANG	MAGN	ANG	MAGN	ANG
500	0.97	-20	5.68	162	0.023	76	0.47	-11
1000	0.93	-41	5.58	143	0.050	71	0.45	-23
2000	0.77	-81	4.76	107	0.086	51	0.36	-38
3000	0.59	-114	4.06	80	0.120	35	0.30	-51
4000	0.48	-148	3.51	52	0.149	18	0.23	-67
5000	0.46	166	3.03	26	0.172	3	0.10	-67
6000	0.53	125	2.65	1	0.189	-14	0.09	48
7000	0.62	96	2.22	-20	0.191	-28	0.24	55
8000	0.71	73	1.75	-39	0.189	-41	0.37	51
9000	0.75	54	1.47	-55	0.184	-46	0.46	42
10000	0.78	39	1.28	-72	0.180	-59	0.51	34
11000	0.82	26	1.04	-86	0.179	-71	0.54	26
12000	0.84	12	0.95	-101	0.177	-82	0.54	17

mance we'd expect from a monotonic (one-pole) low pass filter beyond cutoff. Field-effect transistors are no different in this respect, as Table 2 indicates. Even MMICs, often used as uniform gain blocks, have a pronounced gain roll-off with increasing frequency (see Table 3). Which leaves us with the conclusion that all microwave active devices are inherently low-pass, and will resist producing uniform gain across a wide band of frequencies.

Fortunately, as can be seen in Tables 1 through 3, the input and output reflection coefficients ( $S_{11}$  and  $S_{22}$ ) of most microwave active devices are somewhat greater than zero, which means there's more gain to be had at the higher frequencies, by matching the input and output to the system impedance (typically

50 ohms). Of course, matching the transistor, MMIC or FET at the *higher* frequencies (where gain is lowest) will tend to increase gain at those frequencies, while leaving the device mismatched at the *lowest* frequencies (where there's likely already too much gain) will tend to reduce amplifier gain in that region. Thus a technique widely utilized to obtain wideband performance from microwave transistors is *frequency selective matching*.

In optimizing performance of that commercial 2- to 6-GHz IF amplifier of long ago, my colleagues and I developed a seven step procedure for wideband amplifier design. It's still valid today, and is illustrated here, over that same range of frequencies, in the design of an amplifier using more contemporary active devices and software tools. But before we

**Table 3**

Scattering parameters for a typical silicon monolithic microwave integrated circuit, the Avantek MSA0835, biased at 8 volts  $V_c$  and 36 mA  $I_c$ . Note that, even for these supposedly constant gain devices,  $S_{21}$  decreases quite uniformly with frequency (see text).

FREQ	$S_{11}$		$S_{21}$		$S_{12}$		$S_{22}$	
	MAGN	ANG	MAGN	ANG	MAGN	ANG	MAGN	ANG
100	0.63	-17	42.02	161	0.013	55	0.63	-19
200	0.58	-33	37.52	145	0.021	47	0.56	-37
400	0.49	-56	28.50	119	0.033	54	0.42	-66
600	0.40	-70	21.54	103	0.040	55	0.32	-84
800	0.35	-80	17.01	92	0.050	53	0.24	-98
1000	0.33	-89	13.98	82	0.057	52	0.18	-107
1500	0.30	-111	9.45	64	0.079	51	0.09	-126
2000	0.30	-133	7.03	48	0.098	44	0.07	-141
2500	0.32	-150	5.53	39	0.110	42	0.06	-166
3000	0.34	-170	4.56	26	0.122	36	0.06	-106
3500	0.38	175	3.86	14	0.133	32	0.08	-100
4000	0.39	162	3.33	2	0.146	27	0.12	-101
5000	0.42	132	2.47	-21	0.165	19	0.21	-113
6000	0.52	95	1.94	-45	0.187	7	0.20	-149

begin, some thoughts about software and technique are in order.

**Disclaimer**

There are at least as many techniques for broadbanding microwave amplifiers as there are broadband microwave amplifiers! One common approach involves frequency-selective negative feedback, where the signal at the collector of a common-emitter bipolar stage is fed back to the base through an inductor or other low-pass circuit. This provides a degenerative feedback path at low frequencies, but not higher, and tends to level the gain of the amplifier across the band.

Another popular trick involves selective emitter swamping. Here a bypass capacitor across an emitter-bias resistor is chosen so as to short the resistor at high frequencies (maximizing gain) but not lower in the band. The result is a certain amount of gain leveling through emitter degeneration.

In the amplifier presented here, I achieve wideband performance through frequency selective matching. I make no claims of superiority for this method; I merely maintain that it works for me. If you have another technique which you favor, please write it up for QEX!

**Choose Your Tools Carefully!**

Today we're blessed with a wide variety of software tools to facilitate microwave circuit design and analysis. One of my favorites is a BASIC program for s-parameter design developed by Vatt<sup>1</sup>, and since modified by myself and others, to the point that its own mother wouldn't

recognize it. Unfortunately, like many of my published procedures<sup>2,3,4</sup>, programs written to run on "low-end" machines perform analysis at a single frequency only. That's an acceptable compromise for the typical narrow-band ham application, but just isn't good enough when contemplating wideband design.

To illustrate why, let's evaluate the scattering parameters for a favorite MMIC at its highest characterized frequency, 6 GHz. The numbers are in Table 3. We'll evaluate them using the Scalar Approximation technique which I presented previously<sup>5</sup>. Note that at 6 GHz, the forward voltage transmission coefficient

( $S_{21}$ ) has a magnitude of 1.94, which translates to 5.76 dB of unilateral transducer gain  $G_{tu}$ . The input voltage reflection coefficient ( $S_{11}$ ) magnitude is 0.52, which equates to an input mismatch loss of 1.269 dB, and the corresponding numbers for the output ( $S_{22}$ ) are 0.20 and 0.177 dB, respectively. Adding mismatch losses to transducer gain, we see that the approximate Maximum Available Gain (MAG) from this device at 6 GHz is on the order of 7.4 dB.

Vatt's fine BASIC program, as modified, yields more accurate results than the Scalar Approximation. MAG is really a dB and a half higher than we estimated above, which suggests this device has the potential to make a usable 6-GHz amplifier. Matching stubs are dimensioned for 1/16-inch fiberglass-epoxy printed circuit board (not really the best choice of materials at 6 GHz), as seen in Table 4. The most useful values, open stub wavelength and placement, are highlighted.

Now let's port these wavelengths and s-parameters over to a full-blown swept-frequency microwave circuit analysis program. I use SuperStar<sup>6</sup>, although if you're fortunate enough to have access to SuperCompact<sup>7</sup> or Touchstone<sup>8</sup> you'll get similar results. To build the required circuit file (Table 5) it was necessary to multiply the wavelength dimensions from Fig 4 by 360, as most such software inputs transmission-line lengths in degrees at a specified frequency.

SuperStar swept-frequency analysis of the above circuit file (Fig 1) confirms that we have indeed optimized the MMIC at 6 GHz. Note that the high-frequency (clockwise) ends of the  $S_{11}$  and  $S_{22}$  arcs

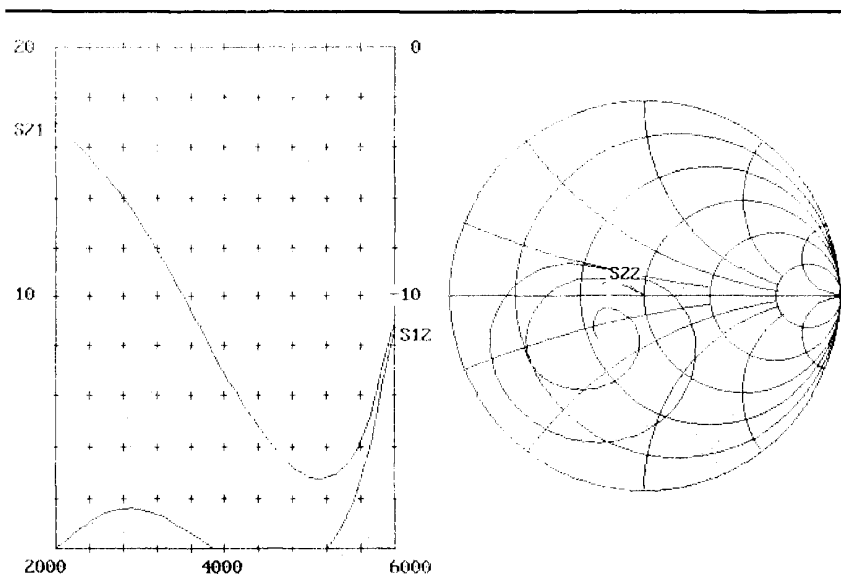

Fig 1—A perfect match at the high-frequency end yields some rather strange swept-frequency results (see text).

<sup>1</sup>Notes appear on page 13.

**Table 4**

**Single-frequency (6 GHz) s-parameter analysis for the MSA0835 MMIC yields a rudimentary amplifier design.**

SMALL-SIGNAL AMPLIFIER DESIGN BY MICROCOMM  
TRANSISTOR PARAMETERS:

S11 = 0.520 / 95.0 Deg  
S12 = 0.187 / 7.0 Deg  
S21 = 1.940 / -45.0 Deg  
S22 = 0.200 / -149.0 Deg  
Zo = 50.0 Ohms

K = + 1.046764  
Gtu = 5.76 dB  
MAG = 8.84 dB  
MSG = 10.16 dB  
GAMMA ms = 0.822 / -97.0 Deg  
GAMMA ml = 0.717 / 140.0 Deg  
INPUT VSWR = 1.00  
OUTPUT VSWR = 1.00

INPUT & OUTPUT WILL BE MATCHED USING 50-Ohm MICROSTRIP

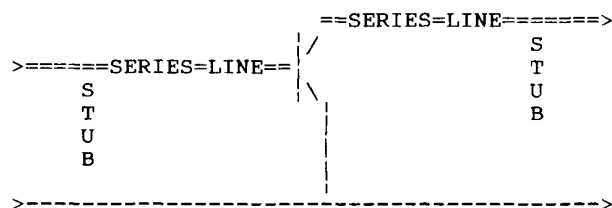

CENTER FREQUENCY OF AMPLIFIER = 6000 MHZ  
DESIGNED FOR 4.8 DIELECTRIC CONSTANT,  
.059 IN. THICK SUBSTRATE

NOMINAL LINE WIDTH IS .109 IN. [2.8 mm]

**INPUT NETWORK**

USING A SHORTED STUB:

STUB WAVELENGTH = .053 LENGTH = 0.055 IN. [ 1.4 mm]  
SERIES WAVELENGTH = .337 LENGTH = 0.346 IN. [ 8.8 mm]

USING AN OPEN STUB:

STUB WAVELENGTH = .197 LENGTH = 0.203 IN. [ 5.2 mm]  
STUB EQUIV SHUNT CAP. = 1.5 pF  
SERIES WAVELENGTH = .433 LENGTH = 0.446 IN. [ 11.3 mm]

**OUTPUT NETWORK**

USING A SHORTED STUB:

STUB WAVELENGTH = .072 LENGTH = 0.074 IN. [ 1.9 mm]  
SERIES WAVELENGTH = .494 LENGTH = 0.509 IN. [ 12.9 mm]

USING AN OPEN STUB:

STUB WAVELENGTH = .178 LENGTH = 0.183 IN. [ 4.7 mm]  
STUB EQUIV SHUNT CAP. = 1.1 pF  
SERIES WAVELENGTH = .117 LENGTH = 0.120 IN. [ 3.1 mm]

**Table 5**

**SuperStar circuit file for testing the single-frequency matching stub design, developed per Vatt (Ref 1).**

This file is : 2-6ghz.amp

```
circuit 2-6ghz.amp
ost aa dg 50 ?70.9      6000
trl bb dg 50 ?155.9     6000
two cc sp 50 '\circuits\star\data\msa0835.836
trl dd dg 50 ?42        6000
ost ee dg 50 ?64        6000
cax aa ee
output
gph aa s21 50 0 20
gph aa s12 50 -20 0
smh aa s11 50
smh aa s22 50
freq
swp 2000 6000 21
```

are right in the middle of the Smith Chart, and the swept gain ( $S_{21}$ ) really coincides with our calculated MAG at 6 GHz. But notice that simply matching the device at the highest operating frequency has failed to provide uniform gain across the operating band. In fact, a pronounced null at 5.1 GHz makes this a less than ideal broadband amplifier. Our actual design procedure is going to have to be quite a bit more interactive, and will of course require either swept-frequency-analysis software, or one heck of a lot of breadboarding.

**STEP 1: Characterize the Active Device**

It's always a good idea to characterize the selected active device, before expending any effort in circuit design. The S-parameters listed in Table 3 are typed into an ASCII data file, which is accessed by the SuperStar analysis software in the circuit file shown at the top of Table 6. The program produces a listing of input and output VSWR, forward and reverse gain, and Rollett's Stability Factor (K), over the selected frequency range, as seen in Table 6. These data, which represent the transducer performance of the active device (and can be similarly found for bipolar junction transistors and FETs), are shown graphically in Fig 2. Note that the forward gain drops from more than 16 dB at the low end of the band, to under 6 dB at the top frequency. Note also that the input match ( $S_{11}$ ) is fair across the band, and the output match ( $S_{22}$ ) is excellent, as seen by its proximity to the middle of the Smith Chart.

But gain and match tell only half the story. Will this device yield a stable amplifier, or will it perhaps oscillate? We have several clues in the Data Table. Note that, at least at the lower operating frequencies, the reverse loss ( $S_{21}$ ) is a scant 3 dB more than the forward gain. Further, stability factor K is less than unity. Stability Circle analysis (Figs 3 and 4) shows regions of the Smith Chart which are cut by the stability circles, which further suggests that the device is only conditionally stable. Unless we take some very deliberate steps to prevent oscillation, we may find this amplifier generating signals of its own.

**STEP 2: Swamp the Output for Stability**

One time-honored technique for improving the stability of only marginally stable devices is resistive swamping. A resistance of carefully chosen value is applied in shunt with either the input or output terminals of the device. The result is to reduce the available gain of the device to just below the threshold of potential instability. Of course, any resistive swamping of a transistor's input will degrade noise figure, thus is to be avoided in receive applications. Similarly, resistive

**Table 6**

**Circuit file (top) and analysis results (bottom) show characteristics of the selected MMIC over the entire 2-6 GHz frequency range.**

This file is : 2-6ghz.amp

```
circuit 2-6ghz.amp
two aa sp 50 '\circuits\star\data\msa0835.836
output
gph aa s21 50 0 20
gph aa s12 50 -20 0
smh aa s11 50
smh aa s22 50
freq
swp 2000 6000 21
```

Run of 2-6ghz.amp === SuperStar === Wed Aug 31 03:27:03 1988

FREQ(MHZ)	INPUT VSWR	S21 dB< ANG	S12 dB	OUTPUT VSWR	K
2000.00	1.857	16.939< 48.000	-20.175	1.151	0.9807838
2200.00	1.877	16.140< 44.906	-19.761	1.138	0.9961811
2400.00	1.915	15.294< 41.167	-19.365	1.130	1.014019
2600.00	1.944	14.513< 36.789	-18.993	1.116	1.031817
2800.00	1.973	13.833< 31.809	-18.633	1.110	1.04432
3000.00	2.030	13.179< 26.000	-18.273	1.128	1.05125
3200.00	2.091	12.585< 21.677	-17.970	1.146	1.057031
3400.00	2.175	12.008< 16.728	-17.671	1.164	1.058996
3600.00	2.228	11.462< 11.879	-17.360	1.193	1.06115
3800.00	2.245	10.938< 7.2282	-17.036	1.232	1.064469
4000.00	2.279	10.449< 2.0000	-16.713	1.273	1.062847
4200.00	2.253	9.8962<-1.5416	-16.504	1.318	1.080762
4400.00	2.251	9.3462<-5.5633	-16.293	1.367	1.095185
4600.00	2.273	8.8108<-10.121	-16.080	1.419	1.104496
4800.00	2.319	8.3065<-15.260	-15.865	1.474	1.106595
5000.00	2.390	7.8539<-21.000	-15.650	1.532	1.098996
5200.00	2.423	7.3687<-24.874	-15.455	1.505	1.121526
5400.00	2.513	6.9017<-29.198	-15.246	1.489	1.13011
5600.00	2.662	6.4662<-33.996	-15.026	1.482	1.122171
5800.00	2.876	6.0784<-39.272	-14.798	1.486	1.095112
6000.00	3.167	5.7560<-45.000	-14.563	1.500	1.046764

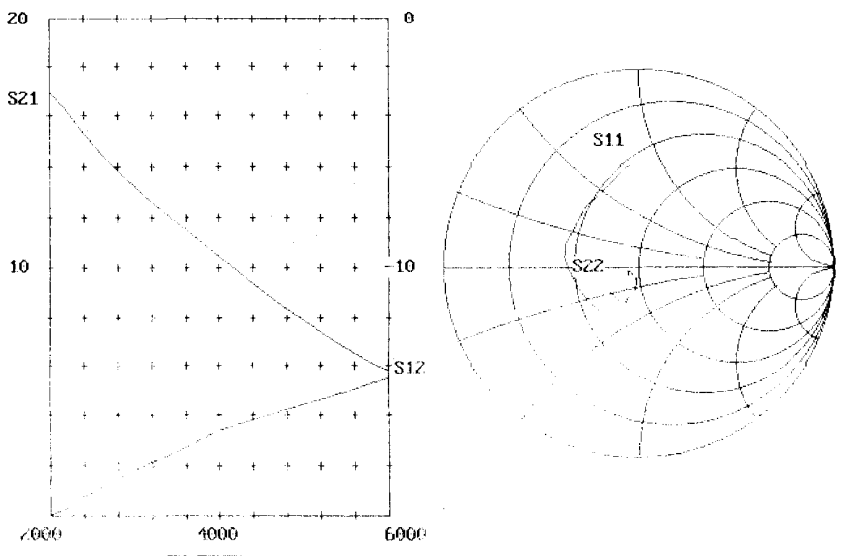

Fig 2—Transducer swept performance of the selected MMIC.

swamping at a transistor's output degrades output power, and is thus to be avoided in transmit applications. The decision of whether to place the swamping resistor at the input or output of the active device is highly application dependent.

The example circuit was originally intended to be utilized as an IF amplifier in a millimeter-wave receiver, hence output swamping was selected. A 100-ohm resistor (in fact, part of the collector bias resistance) was selected, and added to the circuit file for computer analysis, as seen in Table 7. The resulting gain dropped more than one and a half dB, which nudged the Rollet Stability factor above unity across the entire 2- to 6-GHz band. Note that input and output VSWR were slightly degraded in the process. In the words of that old Greek philosopher, Will Rogers, there ain't no free lunch.

Fig 5 shows graphically that gain and match are indeed degraded with resistive swamping. However, Input (Fig 6) and

```

INPUT PLANE STABILITY CIRCLES
FREQ 2000
CENTER 0.9725679
ANGLE -47.83351
RADIUS 1.933582
STABLE INSIDE
FREQ 4000
CENTER 9.086371
ANGLE 22.07593
RADIUS 10.15635
STABLE INSIDE
FREQ 6000
CENTER 2.839247
ANGLE -97.01319
RADIUS 1.809289
STABLE OUTSIDE

```

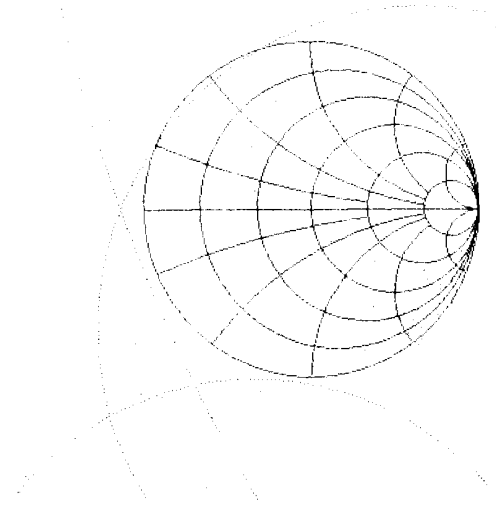

Fig 3—Input stability circles for the naked MMIC indicate regions of potential oscillation (see text).

Output (Fig 7) Stability Circles confirm that the device is now unconditionally stable over the entire operating frequency range.

### STEP 3: Match the Input at the Highest Frequency

S-parameter analysis shows the input of the MMIC/swamping resistor cascade to be somewhat inductive at the higher frequencies; thus, a small amount of capacitance in the form of an open-circuited stub will be applied in shunt with the input terminal. The length of the stub is varied empirically (Table 8) for a reasonable input match at the top of the band. This results in increased high-frequency gain, along with slightly degraded gain and match at the lower frequencies, as seen in Fig 8.

Note the input match ( $S_{11}$ ) curve in Fig 8, which rotates clockwise about the Smith chart with increasing frequency (as do all reflection coefficient curves). The objective in matching the input is to end up with the curve roughly circling the middle of the chart, with a minimum radius. It should also be noted that the matching stub for the swamped MMIC

Table 7

Results of adding a swamping resistor across the output terminals of the MMIC. The device is now unconditionally stable across the band.

This file is : 2-6ghz.amp

```

circuit 2-6ghz.amp
two aa sp 50 '\circuits\star\data\msa0835.836
res bb pa ?100
cax aa bb
output
gph aa s21 50 0 20
gph aa s12 50 -20 0
smh aa s11 50
smh aa s22 50
freq
swp 2000 6000 21

```

Run of 2-6ghz.amp === SuperStar === Wed Aug 31 03:30:12 1988

FREQ(MHz)	INPUT VSWR	S21 dB<	ANG	S12 dB	OUTPUT VSWR	K
2000.00	2.389	15.096<	48.510	-22.019	1.620	1.008833
2200.00	2.364	14.299<	45.280	-21.602	1.621	1.04607
2400.00	2.368	13.456<	41.404	-21.202	1.623	1.085668
2600.00	2.369	12.661<	37.056	-20.844	1.606	1.130241
2800.00	2.377	11.953<	32.275	-20.513	1.573	1.172316
3000.00	2.432	11.269<	26.663	-20.183	1.543	1.202683
3200.00	2.488	10.673<	22.437	-19.882	1.543	1.221843
3400.00	2.581	10.094<	17.584	-19.585	1.544	1.231237
3600.00	2.642	9.5499<	12.875	-19.273	1.552	1.239554
3800.00	2.662	9.0316<	8.4036	-18.942	1.568	1.250228
4000.00	2.709	8.5481<	3.3558	-18.614	1.584	1.25047
4200.00	2.651	8.0154<-	.00839	-18.385	1.619	1.290602
4400.00	2.627	7.4854<-	3.8519	-18.154	1.655	1.323193
4600.00	2.637	6.9700<-	8.2309	-17.921	1.693	1.345431
4800.00	2.684	6.4855<-	13.190	-17.686	1.733	1.353742
5000.00	2.768	6.0528<-	18.749	-17.452	1.775	1.343959
5200.00	2.783	5.6003<-	22.826	-17.223	1.801	1.366322
5400.00	2.872	5.1661<-	27.354	-16.981	1.830	1.364209
5600.00	3.042	4.7635<-	32.358	-16.729	1.864	1.334229
5800.00	3.304	4.4084<-	37.841	-16.468	1.901	1.273276
6000.00	3.682	4.1189<-	43.778	-16.200	1.941	1.179243

**OUTPUT PLANE STABILITY CIRCLES**

FREQ 2000  
 CENTER 0.6119476  
 ANGLE -43.58749  
 RADIUS 1.560798  
 STABLE INSIDE  
 FREQ 4000  
 CENTER 1.514885  
 ANGLE -58.05787  
 RADIUS 2.619934  
 STABLE INSIDE  
 FREQ 6000  
 CENTER 11.06599  
 ANGLE -40.02822  
 RADIUS 12.13707  
 STABLE INSIDE

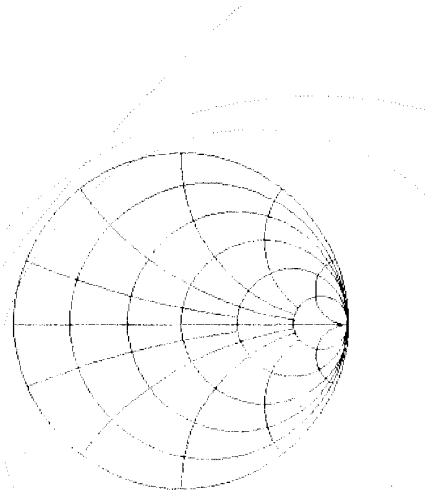

Fig 4—Output stability circles for the MMIC as a transducer further suggest that this device is not unconditionally stable.

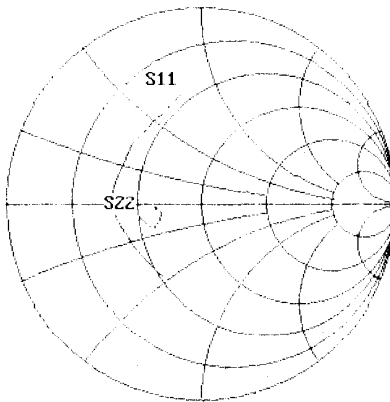
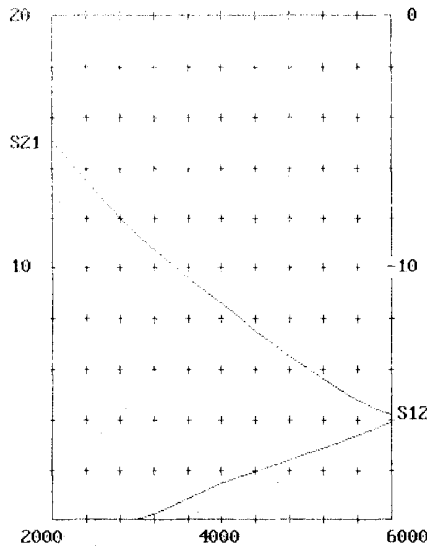

Fig 5—Transducer swept response for the swamped MMIC. Compared to Fig 2, gain is reduced, match is degraded.

bears scant resemblance to the stub which was applied to the MMIC alone, as in Table 6. This is because the transducer characteristics with and without swamping differ considerably, as seen by comparing Figs 2 and 5.

**STEP 4: Match the Output at the Highest Frequency**

The  $S_{22}$  arc in Fig 8 falls very near to the real (nonreactive) axis, somewhat to

the left of the Smith chart's center. One easy way to match the output is to rotate this impedance clockwise one-quarter of the way around the chart, by means of a series microstripline 45 degrees long at the highest operating frequency. This will result in an inductive complex impedance which can be resonated by an open stub, in a manner similar to the input matching circuit.

As seen in Table 9, optimizing the out-

put stub length and placement results in a further gain increase at the high frequencies, a considerable improvement in output VSWR, and a slight degradation in input match due to the  $S_{12}$ -related feedback through the active device.

**STEP 5: Diddle and Tweak**

Every engineer or technician is likely to develop his or her own tweak and peak technique, but all will recognize that input and output tuning are somewhat interactive. This is due to the feedback path between the output and input of any active device, as evidenced by the non-zero Reverse Voltage Transmission Coefficient,  $S_{12}$ . While fine-tuning the stub values, it is useful to be able to view swept gain and match simultaneously. The better microwave circuit analysis software (References 6 through 8) facilitates on-screen tweaking of the sort which actual circuits give you on an automatic network analyzer. Fig 9 shows the performance I achieved by tweaking the length and position of the input and output matching stubs for the 2- to 6-GHz amplifier.

Most advanced circuit analysis programs contain an "optimization" algorithm, in which the user sets target values for key parameters, along with priorities, and identifies component values to be tweaked. To tell the truth, I hardly use them, preferring the manual tuning procedure. Anyone with even passing experience in manually tuning microwave circuits on the bench will have developed an intuition for which way to go on which trimmer to accomplish a given objective. I would suggest that the computer between your ears is still more efficient than the one on your desk, in determining an appropriate trade-off between conflicting requirements.

**STEP 6: Mismatch the Input at the Lowest Frequency**

You will notice in Fig 9 that the low frequency gain is still considerably higher than that achieved higher in the band. We have already raised the high-end gain as far as the s-parameters will allow; if flat response is desired, we're going to have to lower the gain at the bottom of the band. The easiest way to do so is to add a high-pass filter into the circuit, and this is readily accomplished with series capacitance. Since we're going to need dc-blocking capacitors at the input and output of the transistor or MMIC to keep from shorting out the bias, their values can be chosen accordingly.

I chose to mismatch the input at low frequency by adding a small blocking capacitor. I could have achieved the same result by playing with an output capacitance, but in the intended application, this amplifier's output match is the more critical of the two. Whether to perform this frequency shaping at the

**Table 8**

**A matching stub at the input to the MMIC improves high-frequency gain and lowers high-end input VSWR.**

This file is : 2-6ghz.amp

```

circuit 2-6ghz.amp
ost aa dg 50 ?46      6000
two bb sp 50 '\circuits\star\data\msa0835.836
res cc pa 100
cax aa cc
output
gph aa s21 50 0 20
gph aa s12 50 -20 0
smh aa s11 50
smh aa s22 50
freq
swp 2000 6000 21
opt
5800 6000 s11<-20
    
```

Run of 2-6ghz.amp === SuperStar === Wed Aug 31 03:35:59 1988

FREQ(MHz)	INPUT VSWR	S21 dB< ANG	S12 dB	OUTPUT VSWR	K
2000.00	3.019	14.631< 42.531	-22.483	1.437	1.008833
2200.00	3.008	13.824< 38.995	-22.077	1.430	1.04607
2400.00	3.015	12.979< 34.862	-21.679	1.428	1.085668
2600.00	2.989	12.204< 30.282	-21.301	1.417	1.130241
2800.00	2.938	11.538< 25.280	-20.927	1.404	1.172316
3000.00	2.913	10.914< 19.478	-20.538	1.406	1.202683
3200.00	2.886	10.379< 14.976	-20.176	1.429	1.221843
3400.00	2.876	9.8758< 9.8599	-19.803	1.459	1.231237
3600.00	2.822	9.4172< 4.7415	-19.405	1.503	1.239554
3800.00	2.715	8.9919<-3.2252	-18.982	1.563	1.250228
4000.00	2.616	8.6167<-6.0143	-18.545	1.634	1.25047
4200.00	2.406	8.1973<-10.443	-18.203	1.715	1.290602
4400.00	2.213	7.7933<-15.474	-17.846	1.807	1.323193
4600.00	2.034	7.4171<-21.180	-17.473	1.909	1.345431
4800.00	1.869	7.0851<-27.628	-17.087	2.024	1.353741
5000.00	1.719	6.8180<-34.864	-16.686	2.154	1.343959
5200.00	1.478	6.5268<-41.567	-16.296	2.249	1.366322
5400.00	1.295	6.2500<-49.076	-15.897	2.359	1.364209
5600.00	1.237	5.9937<-57.456	-15.499	2.485	1.334229
5800.00	1.377	5.7642<-66.747	-15.112	2.627	1.273276
6000.00	1.665	5.5668<-76.951	-14.752	2.781	1.179243

```

INPUT PLANE STABILITY CIRCLES
FREQ 2000
CENTER 13.98281
ANGLE 113.6428
RADIUS 12.97461
STABLE OUTSIDE
FREQ 4000
CENTER 3.074242
ANGLE -173.9985
RADIUS 1.914122
STABLE OUTSIDE
FREQ 6000
CENTER 1.878942
ANGLE -104.6496
RADIUS 0.8009181
STABLE OUTSIDE
    
```

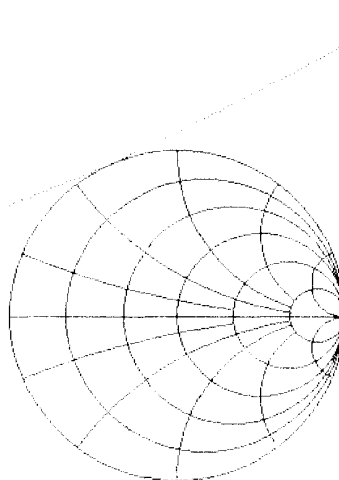

Fig 6—Input stability circles for swamped MMIC show instability regions now all fall outside the limits of real terminating impedances.

input or the output is thus analogous to the decision of whether to swamp for stability at the input or output: it depends upon the application.

As indicated in Table 10, a 1 pF input capacitance lowers the 2-GHz gain by fully four and a half dB, without impacting the gain at the high end. As you would expect by now, this capacitance interacts with other component values in the circuit, and further tweaking of the matching stubs may be necessary to achieve optimum performance. Fig 10 shows the results of that tweaking: a nominal 7.5 dB of gain, with reasonable flatness, across the entire 2- to 6-GHz band. Note that output match is excellent at all frequencies, while input match degrades at the low end of the band.

**STEP 7: Verify Stability of the Final Design**

We've very nearly completed the wide-band microwave amplifier design. All that remains is to once again perform a stability circle analysis, to ensure that our tweaking and peaking hasn't inadvertent-

**Table 9**

**An additional output matching stub improves high-frequency output VSWR, and further raises high-end gain.**

This file is : 2-6ghz.amp

```
circuit 2-6ghz.amp
ost aa dg 50 ?46          6000
two bb sp 50 '\circuits\star\data\msa0835.836
res cc pa 100
trl dd dg 50 ?41          6000
ost ee dg 50 ?47          6000
cax aa ee
output
gph aa s21 50 0 20
gph aa s12 50 -20 0
smh aa s11 50
smh aa s22 50
freq
swp 2000 6000 21
opt
5800 6000 s22<-40
```

Run of 2-6ghz.amp === SuperStar === Wed Aug 31 03:40:55 1988

FREQ(MHz)	INPUT VSWR	S21 dB< ANG	S12 dB	OUTPUT VSWR	K
2000.00	3.118	14.637< 22.188	-22.478	1.427	1.008833
2200.00	3.141	13.835< 16.519	-22.066	1.410	1.04607
2400.00	3.186	12.996< 10.238	-21.663	1.397	1.085668
2600.00	3.205	12.207< 3.5263	-21.298	1.411	1.130241
2800.00	3.203	11.507<-3.5604	-20.959	1.463	1.172316
3000.00	3.236	10.845<-11.411	-20.607	1.529	1.202683
3200.00	3.264	10.294<-17.941	-20.261	1.575	1.221843
3400.00	3.321	9.7775<-25.065	-19.901	1.623	1.231237
3600.00	3.337	9.3096<-32.134	-19.513	1.677	1.239554
3800.00	3.292	8.8820<-39.088	-19.092	1.734	1.250228
4000.00	3.257	8.5150<-46.648	-18.647	1.787	1.25047
4200.00	3.045	8.1278<-52.971	-18.273	1.817	1.290602
4400.00	2.845	7.7721<-59.918	-17.867	1.837	1.323193
4600.00	2.656	7.4631<-67.586	-17.427	1.844	1.345431
4800.00	2.482	7.2207<-76.071	-16.951	1.834	1.353742
5000.00	2.327	7.0694<-85.459	-16.435	1.805	1.343959
5200.00	2.028	6.9478<-95.092	-15.875	1.656	1.366322
5400.00	1.811	6.8563<-105.94	-15.291	1.487	1.364209
5600.00	1.727	6.7888<-118.20	-14.704	1.301	1.334229
5800.00	1.862	6.7290<-132.02	-14.148	1.104	1.273276
6000.00	2.311	6.6458<-147.49	-13.673	1.105	1.179243

```
OUTPUT PLANE STABILITY CIRCLES
FREQ 2000
CENTER 4.825583
ANGLE -19.08287
RADIUS 5.836254
STABLE INSIDE
FREQ 4000
CENTER 112.1479
ANGLE 150.9742
RADIUS 110.9
STABLE OUTSIDE
FREQ 6000
CENTER 4.058536
ANGLE 154.9317
RADIUS 2.927134
STABLE OUTSIDE
```

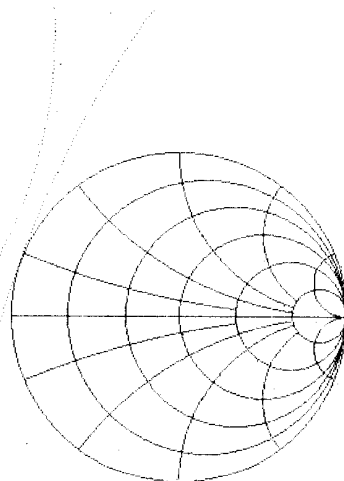

Fig 7—Output stability circles for the swamped MMIC further suggest unconditional stability.



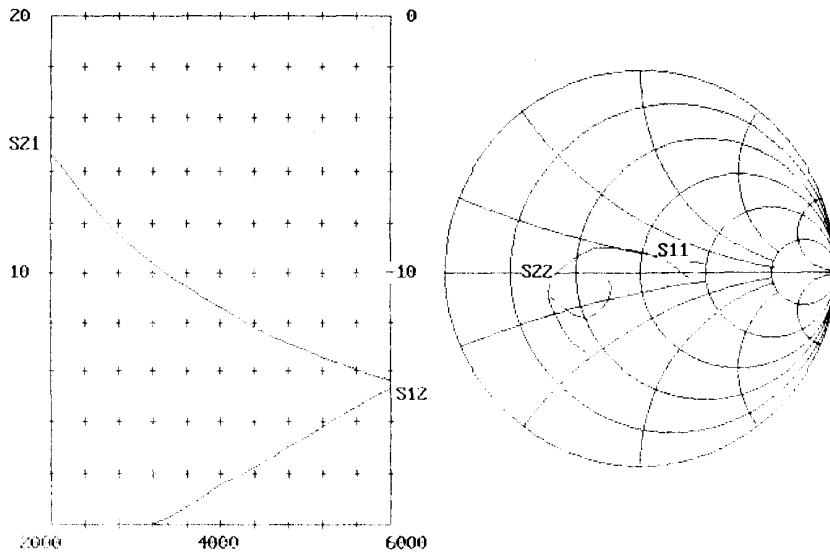

Fig 8—Input matching results in some flattening of the gain curve, by reducing input reflection losses at the higher frequencies.

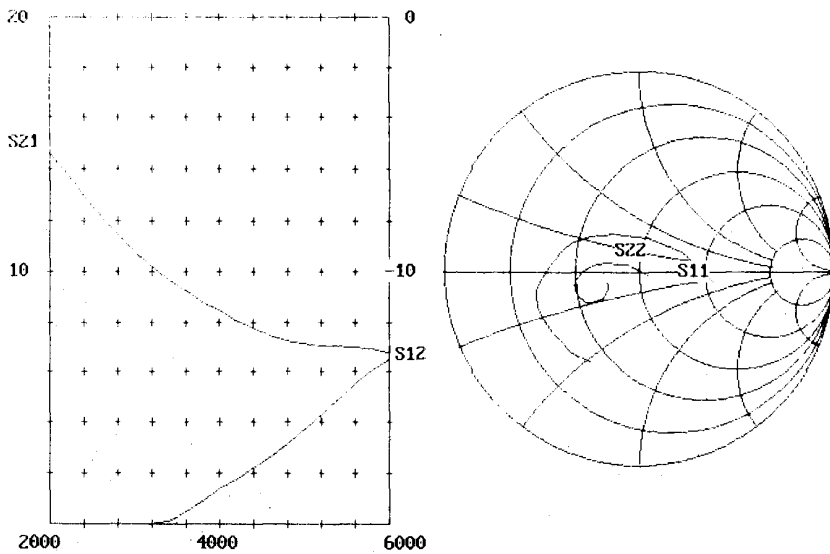

Fig 9—With both input and output matching optimized for high-frequency performance, noticeable flattening of the gain curve begins to occur.

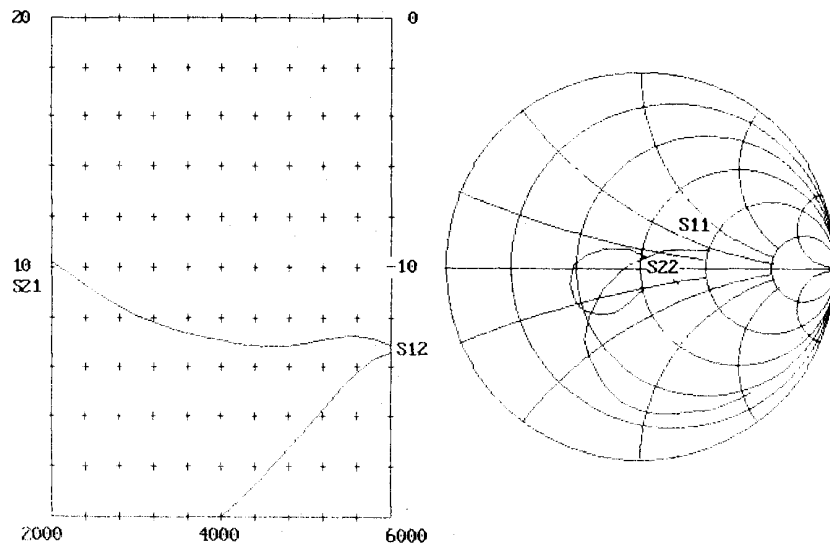

Fig 10—A final tweak to the input trimmer and matching stubs results in fairly flat gain performance across 1½ decades of frequency.

**Table 10**

**Addition of a small input coupling capacitor rolls off low-frequency gain noticeably.**

This file is : 2-6ghz.amp

```

circuit 2-6ghz.amp
cap aa se ?1.002985
ost bb dg 50 ?44.42182 6000
two cc sp 50 '\circuits\star\data\msa0835.836
res dd pa 100
trl ee dg 50 ?44.92084 6000
ost ff dg 50 ?48.92987 6000
cax aa ff
output
gph aa s21 50 0 20
gph aa s12 50 -20 0
smh aa s11 50
smh aa s22 50
freq
swp 2000 6000 21
opt
2000 6000 s21=8
    
```

Run of 2-6ghz.amp === SuperStar === Wed Aug 31 03:48:17 1988

FREQ(MHz)	INPUT VSWR	S21 dB< ANG	S12 dB	OUTPUT VSWR	K
2000.00	13.26	10.163< 56.483	-26.952	1.214	1.008836
2200.00	12.01	9.7496< 49.921	-26.152	1.277	1.046073
2400.00	11.05	9.2523< 42.874	-25.406	1.338	1.085672
2600.00	10.14	8.7911< 35.547	-24.714	1.436	1.130244
2800.00	9.268	8.4101< 27.972	-24.056	1.575	1.172319
3000.00	8.576	8.0453< 19.716	-23.407	1.719	1.202686
3200.00	7.968	7.7719< 12.561	-22.783	1.813	1.221846
3400.00	7.471	7.5189< 4.8782	-22.160	1.902	1.23124
3600.00	6.947	7.3098<-2.8966	-21.513	1.990	1.239557
3800.00	6.367	7.1392<-10.717	-20.835	2.075	1.250231
4000.00	5.842	7.0261<-19.108	-20.136	2.150	1.250472
4200.00	5.094	6.9043<-26.697	-19.496	2.176	1.290605
4400.00	4.424	6.8101<-34.946	-18.829	2.181	1.323195
4600.00	3.816	6.7617<-43.989	-18.129	2.160	1.345433
4800.00	3.260	6.7810<-53.965	-17.391	2.109	1.353743
5000.00	2.752	6.8930<-65.024	-16.611	2.024	1.343961
5200.00	2.101	7.0277<-77.280	-15.796	1.779	1.366323
5400.00	1.559	7.1445<-91.214	-15.003	1.511	1.36421
5600.00	1.139	7.1984<-107.05	-14.294	1.253	1.334229
5800.00	1.369	7.1200<-124.81	-13.757	1.192	1.273277
6000.00	2.128	6.8292<-144.20	-13.490	1.522	1.179243

INPUT PLANE STABILITY CIRCLES

```

FREQ 2000
CENTER 1.167495
ANGLE 44.96665
RADIUS 0.1662359
STABLE OUTSIDE
FREQ 4000
CENTER 1.640618
ANGLE 94.05413
RADIUS 0.5610524
STABLE OUTSIDE
FREQ 6000
CENTER 1.555855
ANGLE 140.4193
RADIUS 2.855936
STABLE INSIDE
    
```

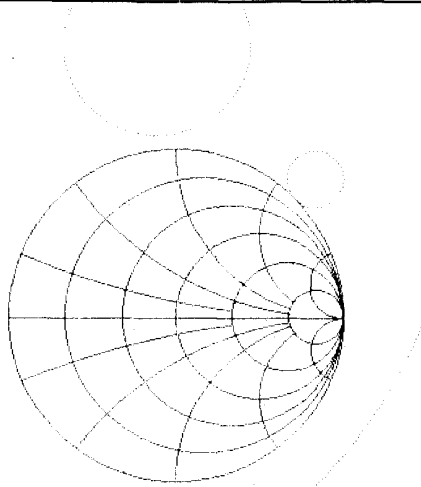

Fig 11—A final check of input stability circles assures input unconditional stability.

**OUTPUT PLANE STABILITY CIRCLES**

FREQ 2000  
 CENTER 3.15799  
 ANGLE 21.42648  
 RADIUS 4.169637  
 STABLE INSIDE  
 FREQ 4000  
 CENTER 1.833191  
 ANGLE 55.09897  
 RADIUS 3.23145  
 STABLE INSIDE  
 FREQ 6000  
 CENTER 2.796849  
 ANGLE -179.1916  
 RADIUS 4.045073  
 STABLE INSIDE

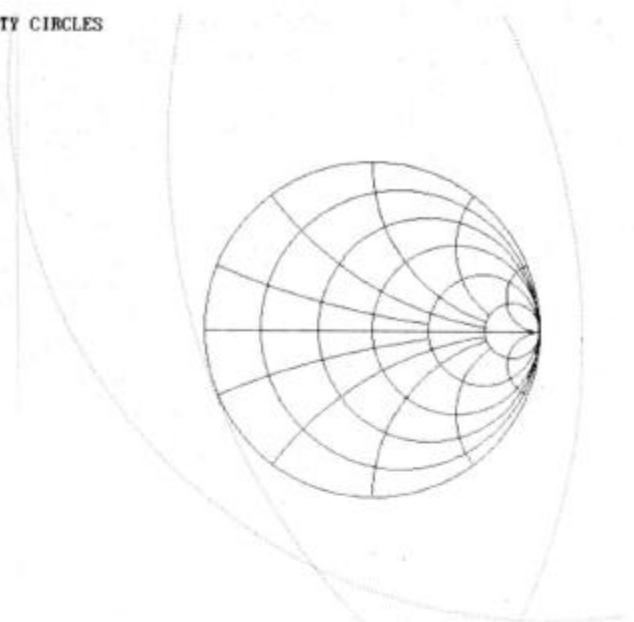

Fig 12—Similarly, output stability circles all fall clear of the Smith Chart, suggesting the stability design goal has been satisfied.

ly pushed our active device toward oscillation. Figs 11 and 12 show the input and output stability circles, respectively. They confirm that this wideband amplifier will remain unconditionally stable across its entire operating frequency range, for any combination of source and load impedances. Were the stability circles to intersect the Smith Chart at any point, the only practical alternative would be to slightly lower the value of the swamping resistor, and start the matching process all over again. Clearly, this iterative process is better performed at the computer than at the workbench!

**References**

- <sup>1</sup>Vatt, Greg, "Computer Aided UHF Preamp Design," *Ham Radio*, Oct 1982, p 28.
- <sup>2</sup>Shuch, H. Paul, "Microstripline Preamp for 1296 MHz," *Ham Radio*, Apr 1975, p 12.
- <sup>3</sup>Shuch, H. Paul, "Low-Cost 1296 MHz Preamp," *Ham Radio*, Oct 1975, p 42.
- <sup>4</sup>Shuch, H. Paul, "Solid State Microwave Amplifier Design," *Ham Radio*, Oct 1976, p 40.
- <sup>5</sup>Shuch, H. Paul, "Smith Chart Part 2: The Scalar Approximation," *Proceedings of the 21st Conference of the Central States VHF Society*, Aug 1987, p 118.
- <sup>6</sup>SuperStar is available from Circuit Busters, Inc, 1750 Mountain Glen, Stone Mountain, GA 30087.
- <sup>7</sup>Super Compact is available from Compact Software, 483 McLean Blvd, Paterson, NJ 07504.
- <sup>8</sup>Touchstone is available from EEsol Inc, 5795 Lindero Canyon Road, Westlake Village, CA 91362.

# PLUG INTO PACKET!

## Simple and Easy.

Here's the easiest packet radio yet, you don't even have to buy a TNC to join the digital revolution. Just let your PC do the work. Plug a PC\*Packet Adapter into any expansion slot and get on the air in minutes, just like an expert. And you'll still be able to use the PC for other work! The complete VHF system is only \$139.95!

## Sophisticated, Too.

When you've mastered the basics, use the PC\*Packet Adapter for simultaneous dual-band HF/VHF, multiconnect, BBS, TCP/IP, DXer's PacketCluster, 2400 baud (and higher). Even use the Developer's Package to write your own packet application.

## Software Included.

Unlike others, DRSI includes all the software you need. The THS terminal package has split screen, file save/send, binary file transfer, print, scroll, review and more.

**2400 BAUD**

Many areas are upgrading their packet nets to this higher speed. DRSI's M-24 modem for 2400 baud connects simply with no modifications to your rig and lets you operate both 1200 and 2400 simultaneously with your present radio. Step up to this new speed for just \$79.95, today!



**DRSI**

2065 Range Road  
 Clearwater, FL 34625  
**ORDERS: 1-800-999-0204**

**Call or Write  
 for complete  
 Product Catalog**